

Anchoring Details

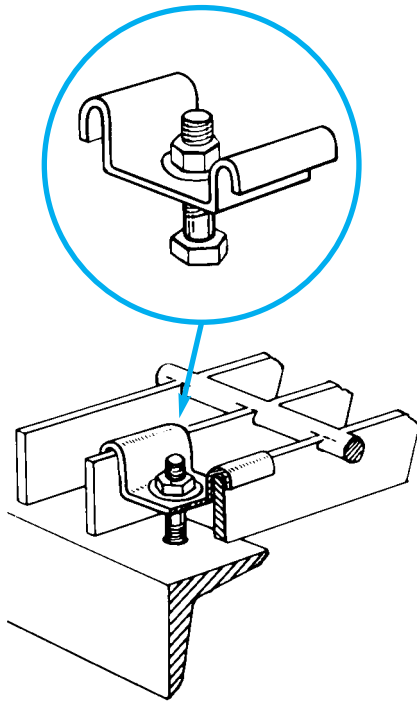

Type H-3 Saddle Clip

The saddle clip bridges two bearing bars and is attached with 1/4" self-tapping bolt, 1/4" self threader, 1/4" weld stud or 1/4" bolt and nut when hole is drilled through supporting flange. Available for 15/16", 1-3/16" and 1-3/8" bearing bar spacings (15, 19 and 22 space) in carbon and stainless steel. Fasteners should be specified separate from clips. (Bolts not included)

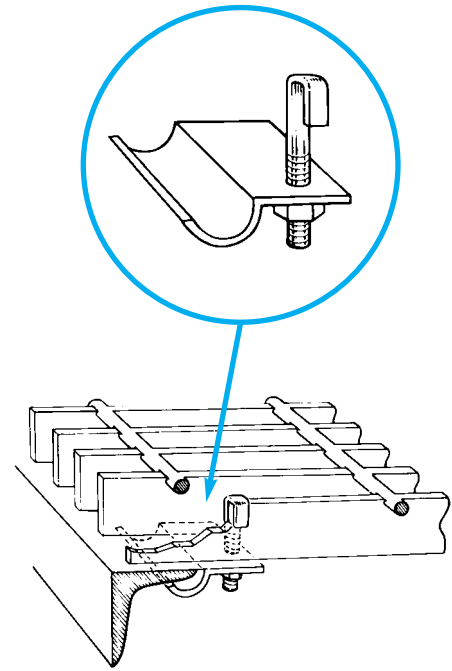

Type H-1 Anchor Clip

A flat head J-bolt secures a preformed plate to the underside of steel bearing bars and structural supporting flange. No drilling needed. Access to underside of grating required for installation. Available in carbon steel. J-bolt is 1/4" x 2-1/2" for grating up to 2-1/4" deep and 1/4" x 3-1/2" for 2-1/2" to 3-1/2" deep grating.

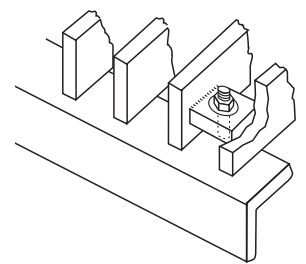
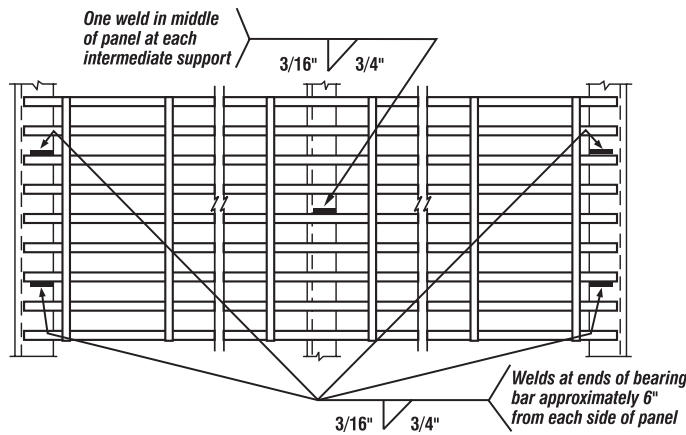
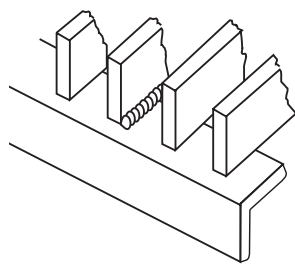

Welds

Recommended for all permanently installed grating panels. Welds should be 3/16" fillet welds, 3/4" long located approximately 6" from each side of panel (4 locations) and one weld in middle of panel at each intermediate support.

Attachment Locations

Attachments should be placed at intermediate supports in the middle of the panels and at the four bearing bar ends, 6" from each side of panel. Welds should be 3/16" fillet welds, 3/4" long. Heavy-Duty grating may require additional welding to meet application needs.

Weld Lugs

Weld lugs may be used for installations where grating is subject to removal. Weld lugs are shop fabricated and must be specified at time of grating order. Fasteners are 1/4" minimum and supplied by others. Location is the same as "Attachment Locations" diagram.